

GUARDIAN & GUARDIANX DP47 NEMA 4 or 4X AIR CONDITIONERS

Model	NEMA Rating	Normally In Stock	UL/CUL Listed or Recognized	95/95 BTU/H Capacity	95/95 Rating BTU/H	Ambient Temp. °F Max./Min.	Volts	* Hz	** Running Amps	Approx. Weight (lbs.)
KNA4C9DP47L	4	Yes	Listed	9000	7400	131/-20	115/100	60/50	19.2/19.2	135
K2NA4C9DP47L	4	Yes	Listed	9000	7400	131/-20	230/200	60/50	9.0/9.0	135
KNA4C9DP47LV	4X	Yes	Listed	9000	7400	131/-20	115/100	60/50	19.2/19.2	135
K2NA4C9DP47LV	4X		Listed	9000	7400	131/-20	230/200	60/50	9.0/9.0	135

* 115V 60 Hz models perform at reduced capacity when operated at 100V 50 Hz.
 ** Rating shown is for operation at maximum ambient temperature.

STANDARD FEATURES

- Baked Powder Finish (NEMA 4 models)
- Built-in Condensate Evaporator
- CFC-Free Refrigerant
- Closed-Loop Cooling
- Condenser Impeller Speed Controller
- Epoxy-Coated Condenser Coil
- Filter
- Heavy-duty Steel Shell
- Internal Corrosion Protection (NEMA 4X models)
- Low Temperature Control Thermostat
- NEMA 4 or 4X Rating Maintained (UL50)
- Six-Foot [1.8m] (minimum) 3-Wire Power Cord
- Stainless Steel Shell (NEMA 4X models)
- UL/CUL Listed

ACCESSORIES AND OPTIONS

- Compressor Short Cycle Protector*
- Enclosure Heater
- Filter Recoating Adhesive
- Lead-Lag Controller
- Programmable Temperature Alarm
- Programmable Thermostat Available
- Remote Thermostat Relay
- Replacement Filters
- Special materials or finishes
- Special motors, line cords or connectors
- Temperature Alarm

* Standard Feature on models with a Programmable Thermostat



**NEMA
TYPE 4 OR 4X
MAINTAINED**



PERFORMANCE

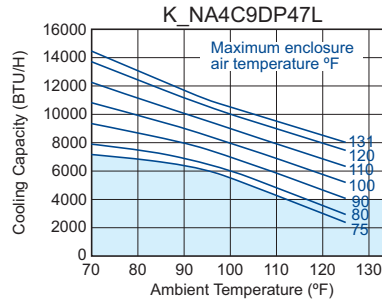

Operation within shaded area not recommended.

- CONDENSER AIR INLET (Ambient Air In)
- CONDENSER OUTLET (Warm Ambient Air Out)
- WARM AIR RETURN FROM ENCLOSURE
- COOL AIR OUTLET TO ENCLOSURE

DRAWINGS

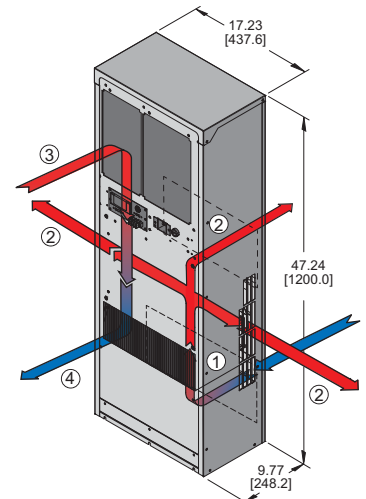
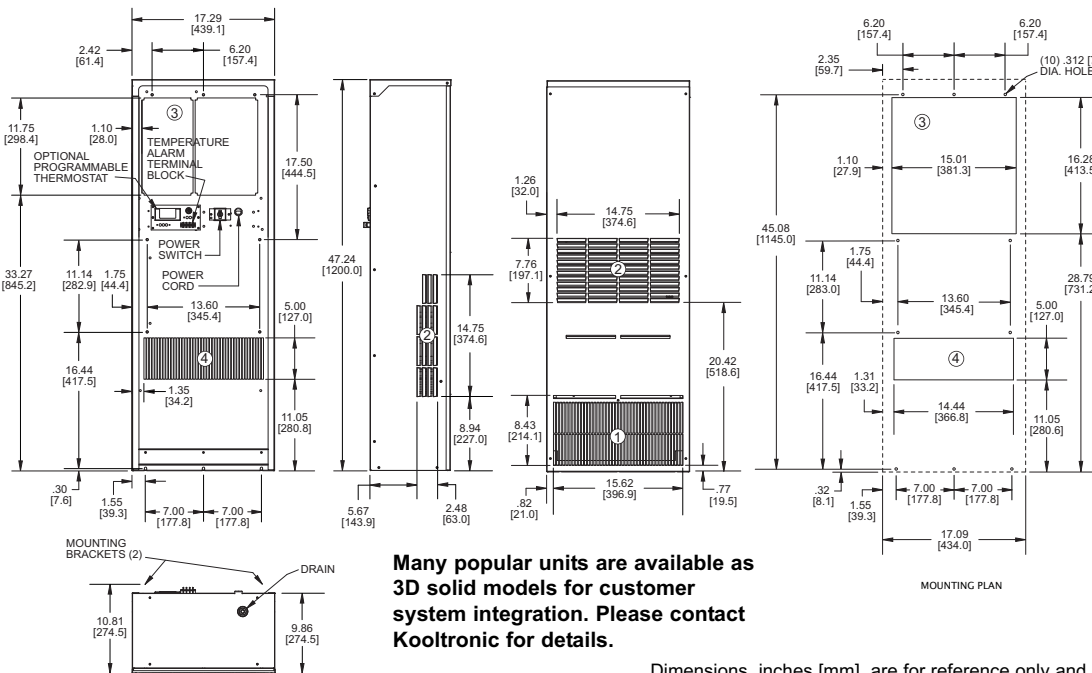

Many popular units are available as 3D solid models for customer system integration. Please contact Kooltronic for details.

Dimensions, inches [mm], are for reference only and are subject to change.

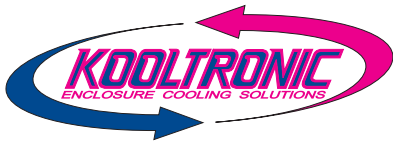

GUARDIAN & GUARDIANX DP47 NEMA 4 or 4X AIR CONDITIONERS

DESCRIPTION

The **Guardian/GuardianX** Indoor/Outdoor Air Conditioners are designed specifically for **NEMA 4** and **4X** enclosure applications that require washdown or are subject to outdoor storm conditions. All **Guardian** models have a **NEMA 4** Rating, offering protection against the hazards of unwanted environmental penetration. The **GuardianX**, with the **NEMA 4X** Rating, is offered with a Stainless Steel Shell and Internal Corrosion Protection.

With Epoxy-coated condenser coils and a closed-loop cooling system, the **Guardian Series** offers added security by providing an operating environment safe from harsh ambient conditions.

The features engineered into all of the **Guardian Series** models make them a tamper-resistant choice for external applications. Combined with a NEMA 4 Rating, with all models UL/CUL Listed, the **Guardian Series** is an excellent choice for telecommunications or other outdoor cabinet applications.

FEATURES AND BENEFITS (STANDARD)

All models UL and cUL Listed, a standard of safety.

Built-in condensate evaporator eliminates the need for a drain (normal operation*).

CFC-free refrigerant provides a zero ozone depletion potential.

Closed-loop cooling provides stable temperature control while excluding dust and humidity from the electrical enclosure.

Condenser impeller cycling provides stable capacity and temperature control.

Condenser filtration to maintain peak thermal performance extends compressor life.

Internal corrosion protection to increase reliability in hostile environments.

Low Temperature Control Thermostat provides energy-efficient operations.

NEMA 12, 3R & 4 ratings for compatibility with listed electrical enclosures.

Stainless steel shell for NEMA 4X corrosive environments (NEMA 4X models).

Both evaporator and condenser coils are epoxy coated, prolonging unit life.

* May not be adequate in extremely high humidity with open or leaky enclosure. Overflow condensate drain fitting and hose are included.

FEATURES AND BENEFITS (OPTIONAL)*

Compressor short cycle protector extends compressor life. (Standard Feature on models with a Programmable Thermostat).

Enclosure heater eliminates damaging condensation, increasing reliability of electrical enclosure components.

Lead-lag control for two air conditioners provides for capacity control, and alternates usage, increasing reliability.

Mounting adapter plates are offered to replace another manufacturer's unit.

Programmable thermostat capable of remote monitoring and control is available.

Programmable temperature alarm to alert if early action required.

Remote monitoring provides temperature data for warning of early action required.

Remote thermostat relay for control by a user-supplied control system.

Special paint finishes*

*Contact KOOLTRONIC for more information.

REPLACEMENT FILTERS

The DP47L-LV filter Part No. is 8001F (8.00" x 16.00" x 0.38" [203.2mm x 406.4mm x 9.7mm]).